

# INTERNATIONAL SOCIETY FOR SOIL MECHANICS AND GEOTECHNICAL ENGINEERING



*This paper was downloaded from the Online Library of the International Society for Soil Mechanics and Geotechnical Engineering (ISSMGE). The library is available here:*

<https://www.issmge.org/publications/online-library>

*This is an open-access database that archives thousands of papers published under the Auspices of the ISSMGE and maintained by the Innovation and Development Committee of ISSMGE.*

# Calculation model of bearing capacity plate-pile foundations under cyclic loading

## Modèle de calcul de la capacité portante des fondations pieu-plaque sous chargement cyclique

I. T. Mirsayapov, I.V. Koroleva

*Department of Bases, Foundations, Dynamics of Structures and Engineering Geology / Kazan State University of Architecture and Engineering, Kazan, Russia*

**ABSTRACT:** Increase the load-carrying capacity and reduce sediment is the use of plate-pile foundations. These foundations are exposed to both static and cyclic loads. The question of influence of cyclic loads on the behavior of combined plate-pile foundations is studied not enough. In connection with this carried out studies of plate-pile foundations under cyclic loading. Developed calculating method of the plate-pile foundation under cyclic loading, considering joint deformation of ground base, piles and plate grillage. Depending on the loading cycle, cyclic loading leads to a redistribution of load between the elements of plate-pile foundation, the ground base at different levels of the plate grillage and the ground massive at space between piles. Joint deformation of the elements of the "plate – piles – surrounding ground massif" system, when piles prevent free deformation of the ground base of a plate, and free deformation of the piles is limited by the ground base of the plate, causes redistribution of forces between the elements of the plate-pile foundation in the process of cyclic loading. Simultaneously with changes in the stress-strain state of the elements of the "plate – pile – ground" system and the redistribution of forces between them under cyclic loading, the mechanical characteristics of the ground change: the specific cohesion between the particles, the angle of internal friction and the modulus of general deformations of the ground. Under cyclic loading conditions, the mobilized shear stress and the limiting shear stress are not constant quantities and change as the number of loading cycles increases.

**RÉSUMÉ:** Augmenter la capacité de charge et réduire les sédiments est l'utilisation de fondations à pieux plats. Ces fondations sont exposées aux charges statiques et cycliques. La question de l'influence des charges cycliques sur le comportement des fondations mixtes pieux-plaques n'est pas suffisamment étudiée. Dans le cadre de cette étude, des études ont été menées sur les fondations à pieux en plaques soumis à un chargement cyclique. Méthode de calcul développée de la fondation pieu-plaque sous chargement cyclique, prenant en compte la déformation conjointe de la base du sol, des pieux et du grillage de plaque. En fonction du cycle de chargement, le chargement cyclique entraîne une redistribution de la charge entre les éléments de la fondation plaque-pieu, la base du sol à différents niveaux du grillage de la plaque et le sol massif entre les piles. La déformation commune des éléments du système «radeau - pieux - massif du sol environnant», lorsque les pieux empêchent la déformation libre de la base du sol d'un radeau et que la déformation libre des pieux est limitée par la forces entre les éléments de la fondation radier-pile lors du processus de chargement cyclique. Simultanément aux modifications de l'état de contrainte-déformation des éléments du système "radier - pieu - sol" et à la redistribution des efforts entre eux sous chargement cyclique, les caractéristiques mécaniques du changement de sol: la cohésion spécifique entre les particules des frottements internes et du module des déformations générales du sol. Dans des conditions de charge cycliques, la contrainte de cisaillement mobilisée

et la contrainte de cisaillement limite ne sont pas des quantités constantes et changent avec l'augmentation du nombre de cycles de charge.

**Keywords:** Plate-pile foundations; specific cohesion; cyclic loading; stress-strain state; ground space between piles

## 1 INTRODUCTION

The search for optimal cost-effective design solutions contributes to the behaviour of experimental and theoretical studies of changes in the stress-strain state of the system “plate-pile foundation – the soil between piles”.

In modern conditions in the construction of buildings and structures the tendency to increase the load on soil bases and the use of weak soils as bases contributed to the fact that one of the most common ways to increase bearing capacity and reduce settlements is the use of plate-pile foundations. Such foundations and their bases, along with static ones, are subjected to cyclic loads, which in some cases are the main determinants in the safe operation of buildings and structures. At the same time, the issue of the effect of cyclic loads on the behaviour of the combined plate-pile foundations has not been adequately investigated.

In this connection, experimental (Mirsayapov, 2014) and theoretical studies of the strength and deformability of the “plate – piles – surrounding ground massif” system, which is part of the plate-pile foundation, were carried out under cyclic loading.

## 2 THE STRESS-STRAIN STATE OF THE PILE FOUNDATION

The stress-strain state of the pile foundation of the plate-pile foundation is very complex. In such a base, materials with different strength and deformation properties are jointly deformed (Ter-Martirosyan, 2012). The deformations

developing of the pile foundation under cyclic loading will occur under the conditions of the interaction of soil and piles in coherent conditions:

a) free ground deformations are held on by piles;

b) free deformation of the pile is prevented by the surrounding soil.

As a result of this interaction between the elements, an additional stress state arises in the pile foundation and a redistribution of forces between the soil and the piles occurs under cyclic loading. At the same time, the stress in the piles increases, and in the soil between the reinforcing elements decrease in comparison with the first cycle.

In this case, the current stresses in the pile foundation are represented as:

$$\sigma_p^{max}(N) = \sigma_p^{max}(N_1) + \Delta\sigma_p(N) \quad (1)$$

$$\sigma_{gr}^{max}(N) = \sigma_{gr}^{max}(N_1) - \Delta\sigma_{gr}(N) \quad (2)$$

Where  $\sigma_p^{max}(N_1)$  and  $\sigma_{gr}^{max}(N_1)$  (kPa) are maximum cycle stresses at the first loading cycle in piles and soil, respectively;  $\Delta\sigma_p(N)$  and  $\Delta\sigma_{gr}(N)$  (kPa) are additional stresses that occur in the pile foundation in the process of cyclic stress in the piles and in the soil, respectively.

In the pile foundation, the pile, due to its adhesion along the side surface with the surrounding soil, becomes an internal bond preventing the free deformation of the soil between piles under cyclic loading. Constrained deformations of the soil vibro-creep lead to the

appearance of additional internally balanced stresses in the pile foundation. In this case, tensile stresses arise in the soil, and compression stresses occur in piles. Under the influence of the difference in deformations of the free vibro-creep of the soil and piles, the constrained deformation of the vibro-creep of the soil in the space between piles is represented as:

$$\Delta\varepsilon_{pl}(N) = \Delta\varepsilon_{pl}^{gr}(N) - \Delta\varepsilon_{pl}^p(N) \quad (3)$$

Where  $\Delta\varepsilon_{pl}(N)$  is additional (residual) deformations the pile foundation's vibro-creep;  $\Delta\varepsilon_{pl}^{gr}(N)$  is free deformations of soil vibro-creep;  $\Delta\varepsilon_{pl}^p(N)$  is free deformation of vibro-creep pile material.

Thus the averaged additional tensile stresses in the soil:

$$\Delta\sigma_{gr}(N) = \Delta\varepsilon_{pl}(N) \cdot E'_0(N) \quad (4)$$

Where  $E'_0(N)$  (kPa) is modulus of soil deformation under cyclic loading.

Deformations  $\Delta\varepsilon_{pl}(N)$  for piles are elastic, and therefore compressive stresses occur:

$$\Delta\sigma_p(N) = \Delta\varepsilon_{pl}(N) \cdot E_p(N) \quad (5)$$

Where  $E_p(N)$  (kPa) is elastic modulus of pile material.

The equilibrium equations of internal forces from the additional stress state of a symmetrical pile foundation have the form:

$$\Delta\sigma_p(N) \cdot A_p = \Delta\sigma_{gr}(N) \cdot A_{gr} \quad (6)$$

Where  $A_p$  (m<sup>2</sup>) is a total cross-sectional area of piles within the pile foundation field under consideration;  $A_{gr}$  (m<sup>2</sup>) is soil basement area.

Based on (6), after a series of simplifications, we obtain analytical expressions for determining additional (residual) stresses:

– in the soil between piles

$$\Delta\sigma_{gr}(N) = \frac{\varepsilon_{pl}^{gr}(N) \cdot E_p(N) \cdot \frac{A_{pl} \cdot n}{A_{gr}}}{1 + \frac{E_p(N) \cdot A_{pl} \cdot n}{E_{gr}(N) \cdot A_{gr}}} \quad (7)$$

– in piles:

$$\Delta\sigma_p(N) = \frac{\varepsilon_{pl}^{gr}(N) \cdot E_p(N)}{1 + \frac{E_p(N) \cdot A_{pl} \cdot n}{E_{gr}(N) \cdot A_{gr}}} \quad (8)$$

Where  $A_{pl}$  (m<sup>2</sup>) is a cross-sectional area of one pile;  $n$  is total number of piles in the calculated base area.

### 3 THE EQUATIONS OF THE MECHANICAL STATE OF THE SYSTEM “PLATE – PILE – SOIL”

For the analytical description of the non-free deformation process of the system “plate – pile – soil” elements, a design scheme is adopted (Figures 1 & 2), on the basis of which the equations of the mechanical state of the soil and the system “plate – pile”, as well as the equilibrium equations of forces, are developed.

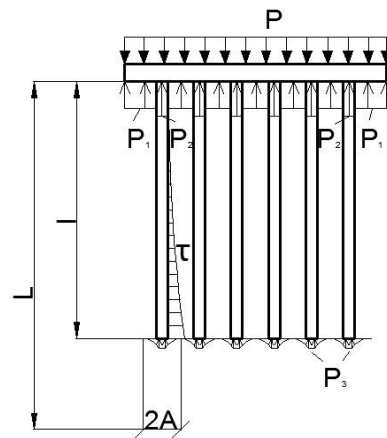

Figure 1. The calculating scheme of the interaction of plate-pile foundation with an array of soil

The joint solution of these equations makes it possible to obtain the desired values of the settlement of the base and the bearing capacity of the plate-pile foundation under cyclic loading.

To simplify the calculation, the accepted calculation scheme consists of a pile, the surrounding soil and the part of the plate falling on one pile (Figure 2). The behaviour of the main components of the stress-strain state of such a cell will correspond to the behaviour of the pile in the plate-pile foundation.

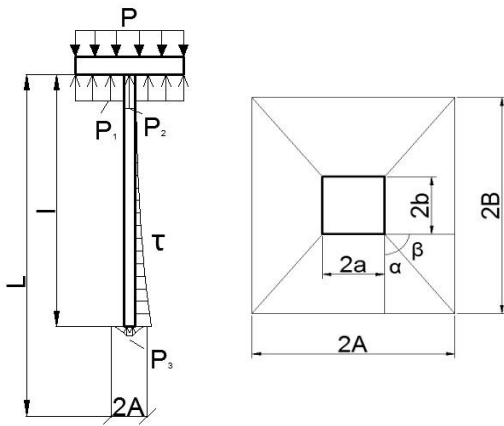

Figure 2. The calculating scheme of the interaction of a single pile with a homogeneous array of soil with a size  $2A \times 2B$

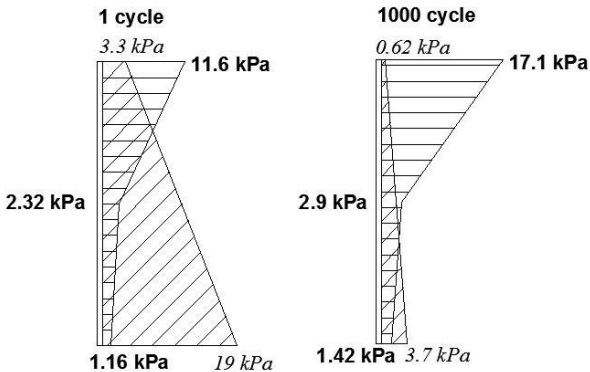

Figure 3. Distribution diagrams of mobilized tangential stress and ultimate shear stress

Sizes of the considered cell is  $2A \times 2B \times L$ , pile sizes is  $2a \times 2b \times l$ . At the cell boundaries, the conditions of free vertical movement are accepted. At the bottom of the considered cell, the complete absence of displacements was assumed.

To solve the problem, it is necessary to find four unknowns –  $p_1, p_2, p_3$  и  $\tau_0$  (Figure 2).

$$\left\{ \begin{array}{l} p \cdot AB = p_2(N) \cdot ab + \\ + p_1(N) \cdot (AB - ab); \\ p_2(N) \cdot ab = p_3(N) \cdot ab + \\ + K_\tau \cdot l \cdot (1 - 4e^{-\alpha l}); \\ K_1 \left(1 - \frac{l}{L}\right) + K_2 + K_3 = K_4; \\ K_1 + (K_2 + K_3)e^{-\alpha l} = \\ = \frac{K_\tau \cdot l}{ab \cdot E_p} + \frac{K_\tau \cdot e^{-\alpha l}}{ab \cdot \alpha \cdot E_p} + \\ + \frac{p_3(N) \cdot l}{E_p} + K_4 - \frac{K_\tau}{ab \cdot \alpha \cdot E_p}, \end{array} \right. \quad (9)$$

Where  $p_1(N) = \sigma_{gr1}^{max}(N) - \Delta\sigma_{gr}(N)$  (kPa) are stresses in the soil under the plate;  $p_2(N) = \sigma_p^{max}(N) + \Delta\sigma_p(N)$  (kPa) are stresses at the top of the pile;  $p_3(N) = \sigma_{gr3}^{max}(N) - \Delta\sigma_{gr}(N)$  (kPa) are stresses under pile heel;

$$K_\tau = \frac{\tau_0(N) \cdot (a+b)}{\alpha}; \quad K_1 = \frac{p_1(N) \cdot \beta \cdot gr \cdot L}{E_{gr}(N)};$$

$$K_2 = \frac{k_1 \cdot \tau_0(N) \cdot (A-a)}{3G_{gr}(N)}; \quad K_3 = \frac{k_2 \cdot \tau_0(N) \cdot (B-b)}{3G_{gr}(N)};$$

$$K_4 = \frac{\omega \cdot \alpha \cdot p_3(N) \cdot (1 - \nu_{gr}) \cdot k(l)}{G_{gr}(N)}; \quad \tau_0(N) = \tau_0(N) \cdot e^{-\alpha z}$$

(kPa) are shear stresses under cyclic loading;  $\tau(z) = \tau_0(N) \cdot e^{-\alpha z}$  (kPa) are shear stresses;  $\alpha = 5l^{-1}$  is a angle;  $l$  (m) is a pile length.

The solution of the system of equations (9) allows to find the magnitude of the stresses, arising in the pile shaft, in the soil under the plate and under the lower end of the piles under cyclic loading.

The zones of maximum equilibrium, taking into account the stiffness of the pile material, are determined by the intersection point of the diagrams of the mobilized shear stress  $\tau_0(N)$  and the ultimate shear stress  $\tau_0(N)$  (Figure 3). The

load distribution between the side and front surfaces of the pile and its base depends on the maximum load of the cycle, the amount of unloading and the number of loading cycles. Under cyclic loading, the ultimate shear stress  $\tau_z^*(N)$  and the mobilized shear stress  $\tau_0(N)$  change as the number of loading cycles  $N$  increases (Figure 3). The ultimate shear stress  $\tau_z^*(N)$  under cyclic loading is calculated by the formula:

$$\tau_z^*(N) = \gamma \cdot z \cdot \tan \varphi(N) + c(N) \quad (10)$$

Where  $\varphi(N)$ (Grad) is the internal friction angle of the soil under cyclic loading;  $c(N)$  (kPa) is specific cohesion of the soil under cyclic loading.

The specific cohesion of the soil and the angle of internal friction of the soil under cyclic loading decrease (Mirsayapov, 2010, 2015, 2016) and can be calculated using the formulas:

$$\begin{aligned} c(N) &= \\ &= c \cdot m(t_1 \tau_1) \cdot \lambda(t_1 \tau_1) \times \\ &\times \sqrt{\frac{k(\tau_1)}{k(t)} + \frac{1}{1+k(\tau_1)} \cdot c(t_1 \tau)} \end{aligned} \quad (11)$$

$$\varphi(N) = 2\alpha(N) - \frac{\pi}{2} \quad (12)$$

Important for the redistribution of efforts in the system is the ratio:

$$\tau_0(N) \leq \tau_z^*(N) \quad (13)$$

Depending on the ratio (13) is a redistribution of forces in the soil between the side surface and under the lower end of the pile, as well as under the plate. If condition (13) is not satisfied, the redistribution of forces from the soil on the side surface of the pile to the ground begins under the plate and under the lower end of the pile.

Experimental studies (Mirsayapov, 2014) have been carried out on the Department of Bases, Foundations, Dynamics of Structures and Engineering Geology at KSUAE, which

illustrate that depending on the length of the pile, the heel level may have a different share of the load, since in the case of increasing the length of the pile, increases the area of the side surface.

Stresses arising in the ground under the plate can be found by the formula:

$$p_1(N) = (p \cdot AB - p_2(N) \cdot ab) \times (AB - ab)^{-1} \quad (14)$$

Strain at the top level in the pile can be expressed as follows:

$$\begin{aligned} p_2(N) &= (ab \cdot K_5 + a \cdot K_6 \cdot K_7)^{-1} \times \\ &\times \left( \begin{aligned} &P \cdot AB(AB - ab) \cdot K_5 + \\ &+ 0,33K_7 \times \\ &\times ((A - a) \cdot k_1 + (B - b) \cdot k_2) + \\ &+ K_6 \cdot K_7 \cdot l \cdot \alpha^{-1} \times \\ &\times (-4 + (a + b)b^{-1} \cdot e^{-\alpha l}) \end{aligned} \right) \end{aligned} \quad (15)$$

Where  $K_5 = G_{gr}(N) \cdot L \cdot \beta_{gr}(1 - l \cdot L^{-1})$ ;  $K_6 = \omega(1 - \nu_{gr}) \cdot k(l)$ ;  $K_7 = E_{gr}(N) \cdot (AB - ab) \cdot \tau_0(N)$ ;  $G_{gr}$  (kPa) is soil shear modulus;  $k(l)$  is dimensionless coefficient taking into account the influence of the depth of application of a rigid stamp on its length;  $\omega$  is punch shape factor;  $\nu_{gr}$  is Poisson's ratio.

Stress under the heel of the pile can be calculated by the formula:

$$p_3(N) = p_2(N) + K_8(1 - e^{-\alpha l}) \quad (16)$$

Where  $K_8 = (a + b) \cdot l \cdot \tau_0(N)(a \cdot b \cdot \alpha)^{-1}$ .

The shear stress  $\tau_0(N)$  can be expressed as follows:

$$\tau_0(N) = \frac{a \cdot b(p_3(N) - p_2(N)) \cdot \alpha}{(a + b) \cdot l(4e^{-\alpha l} - 1)} \quad (17)$$

The bearing capacity of the base, depending on the relation (13), is estimated from the conditions:

$$p_2(N) \leq \sigma_{1u}(N), \quad (18)$$

$$p_3(N) \leq \sigma_{1u}(N). \quad (19)$$

Functional relation  $\sigma_{1u}(N)$  in accordance with (Mirsayapov, 2016) is adopted:

$$\begin{aligned} \sigma_{1u}(N) = & 4 \cdot A_{sh} \times \\ & \times [\sigma_V(t, t_1, N) \times \cos \alpha_1(t, t_1, N) + \\ & + \tau_V(t, t_1, N) \cdot \sin \alpha_1(t, t_1, N)] \end{aligned} \quad (20)$$

Where  $A_{sh} = b^2 \cdot (4 \cos \alpha_2(t, t_1, N))^{-1}$  (m<sup>2</sup>) is surface area of the lateral faces of the soil pyramid;  $A_1 = b^2$  (m<sup>2</sup>) is a cube face area;  $\alpha_1(t, t_1, N)$  (kPa) is the time-varying angle of the slope;  $\alpha_2(t, t_1, N)$  (kPa) is the time-varying angle of inclination of the soil shear pad;  $\sigma_V(t, t_1, N)$  (kPa) are normal stresses in the soil;  $\tau_V(t, t_1, N)$  (kPa) are shear stresses at the site of maximum equilibrium in the soil.

#### 4 CONCLUSIONS

Joint deformation of elements of the system “plate – piles – surrounding soil massif”, when the free deformation of the soil base of the plate is impeded by piles, and the free deformation of the piles is limited by the soil base of the plate, causes a redistribution of forces between the elements of the plate-pile foundation in the process of cyclic loading.

Simultaneously with the change in the stress-strain state of the system “plate grillage – piles – soil” under cyclic loading, the mechanical characteristics of the soil change: specific adhesion, the angle of internal friction and modulus of total deformations of the soil.

Under cyclic loading conditions, the ultimate tangential and mobilized shear stresses are not constant values and change as the number of loading cycles increases.

#### 5 REFERENCES

- Mirsayapov, I.T., Shakirov, M.I. 2014. Experimental studies of bearing capacity and sediment of foundations of slab-pile foundations under cyclic loading. *Prospective directions for the development of theory and practice in rheology and in soil mechanics: Proceedings, XIV Intern. Rheology Symposium* (Eds: Mirsayapov, I.T., Koroleva, I.V.), 68-74. Publisher KSUAE, Kazan.
- Ter-Martirosyan, Z.G., Strunin, P.V. 2012. The interaction of a single pile with a uniform layer of soil of limited size. *Construction - the formation of the living environment: Sat. Works XIV Intern. scientific-practical. conf. young scientists, doctoral students and graduate students* (Eds: Ter-Martirosyan, Z.G. & all.), 659-662. Publisher MGSU, Moscow.
- Mirsayapov, I.T., Koroleva, I.V. 2010. Features of the deformation of clay soils under cyclic three-axis compression, *Intern. Journal of Geotechnics* **6**, 64–67.
- Mirsayapov, I.T., Koroleva, I.V. 2015. Clayey soils rheological model under triaxial regime loading. *Geotechnical Engineering for Infrastructure and Development: Proceedings, XVIIth European Conf. on Soil Mechanics and Geotechnical Engineering* (Eds: Smith, A.L. & all), 632-638. Elsevier, Edinburgh.
- Mirsayapov, I.T., Koroleva, I.V. 2016. Strength and Deformability of Clay Soil Under Different Triaxial Load Regimes that Consider Crack Formation, *Soil Mechanics and Foundation Engineering J.* **53**, **1**, 5–11.